

G52A

QorIQ Enhanced Network CPU Board CompactPCI Serial

- » **Freescall QorIQ, up to 12 cores**
- » **Up to 12 GB DDR3 DRAM soldered, ECC**
- » **Standard front I/O: 2 10 Gb Ethernet, 1 Gb Ethernet, 1 USB 2.0 host, 1 USB configuration port (RS232)**
- » **Standard rear I/O: 14 PCIe lanes, 1 USB 2.0, 2 SATA, 3 Gb Ethernet**
- » **4 HP system master and peripheral slot**
- » **PICMG CPCI-S.0 CompactPCI Serial**
- » **microSD card slot**
- » **CPU TDP from 32W to 61W**
- » **Board Management Controller**
- » **Watchdog**



New Generation of CPU Boards

The G52A is a high-performance multicore CPU platform based on Freescale QorIQ T4x series. The G52A is a new branch of CPU boards for CompactPCI Serial specifically designed for high data bandwidth based on PCIe 3.0, PCIe 2.0 and Gigabit Ethernet via the backplane. The G52A provides high data bandwidth on the front panel via two 10 Gigabit Ethernet interfaces on M12 connectors or on RJ45 connectors (on request). The G52A paired with I/O cards can be ideally used for transferring data from and to storage media, the Internet via LTE, WiFi, copper or optical Ethernet. Its up to 12 processor cores make the board ideally suited for virtualization applications. Serial interfaces at the rear I/O connectors are one USB 2.0, two SATA interfaces, three PCI Express x4 links and one PCI Express x2 link and three Gigabit Ethernet interfaces.

Three-channel DDR3 DRAM

The memory configuration of the G52A includes a fast DDR3 DRAM with ECC which is soldered to the board to guarantee optimum shock and vibration resistance. A microSD card device offers space for user applications or can be used as a local boot medium.

Board Supervision

A board management controller provides thermal supervision of the processor and a watchdog for the operating system. The G52A operates in Linux environments or as a development option in VxWorks or QNX environments.

Perfect for Harsh Environments

The G52A comes with a tailored heat sink within 4 HP height. All components are soldered for protection against shock and vibration according to applicable DIN, EN or IEC industry standards. The G52A is also ready for coating so that it can be used in humid and dusty environments and has a guaranteed minimum standard availability of 15 years. These features make the G52A perfectly suited for harsh environments.

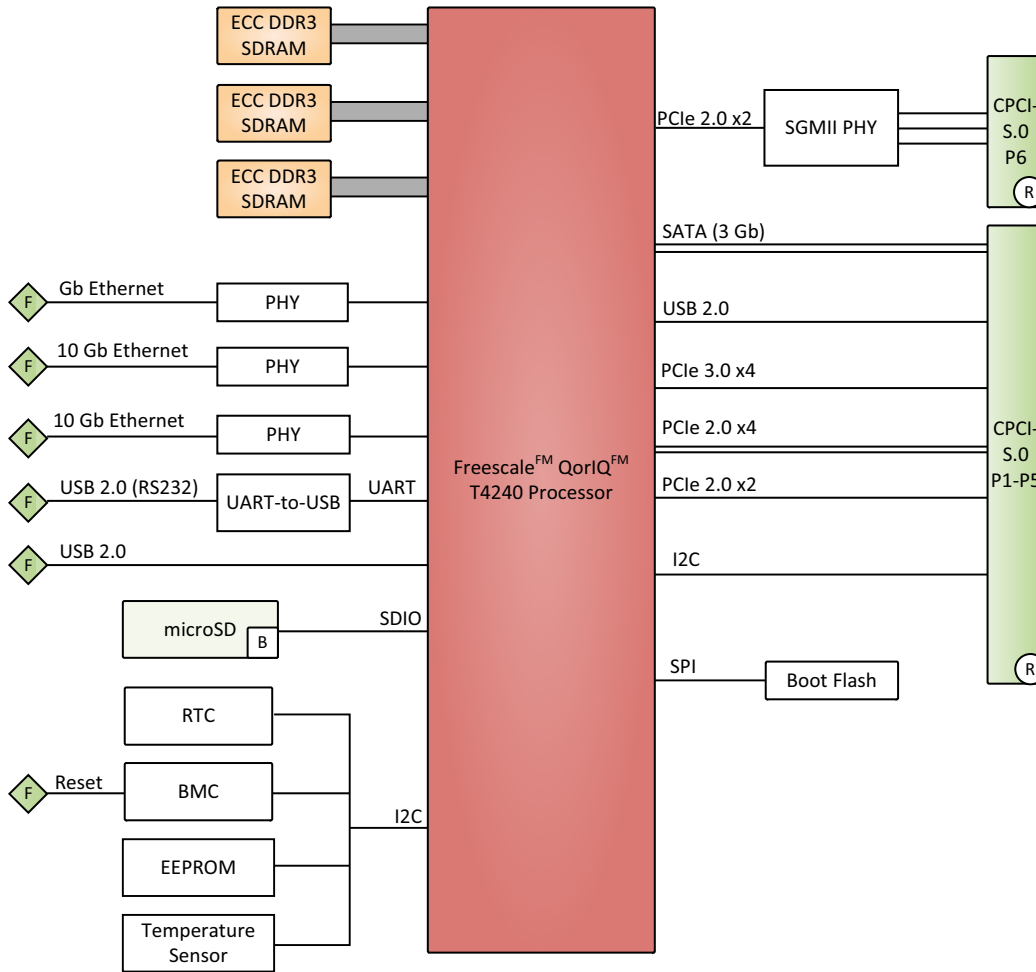

F Front
 R Rear
 B Onboard
 SA SA-Adapter™
 Options

CPU

- The following CPU types are available:
 - Freescale QorIQ T4240, twelve cores, 1.5 to 1.8 GHz
 - Freescale QorIQ T4160, eight cores, 1.5 to 1.8 GHz (on request)
 - Freescale QorIQ T4080, four cores, 1.5 to 1.667 GHz (on request)

Memory

- System Memory
 - Soldered DDR3, ECC support
 - Up to 3 channels
 - Up to 12 GB
- Boot Flash
 - 16 MB

Mass Storage

- The following mass storage device can be assembled:
 - microSD card (up to 32 GB)

Front Interfaces

- USB
 - One Series A connector, USB 2.0
 - One RS232 configuration port implemented as a USB 2.0 device interface
- Ethernet
 - Two 8-pin M12 connectors, X-coded, 10GBASE-T, or
 - Two RJ45 connectors, 10GBASE-T (on request)
 - One 8-pin M12 connector, X-coded, 1000BASE-T, or
 - One RJ45 connector, 1000BASE-T (on request)
 - One link and activity LED per Ethernet channel
- Front-panel LED for board status
- Hot-plug LED
- Reset button

Rear Interfaces

- SATA
 - Two channels, SATA Revision 2.x
- USB
 - One channel, USB 2.0
- Ethernet
 - Three channels, 1000BASE-T
- PCI Express
 - Two x4 links, PCIe 2.x
 - One x2 link, PCIe 2.x
 - One x4 link, PCIe 3.x

Supervision and Control

- Board controller
- Watchdog timer
- Temperature measurement
- Real-time clock with supercapacitor or battery backup
 - Data retention of supercapacitor: tbd

Backplane Standard

- Compliance with CompactPCI Serial PICMG CPCI-S.0 Specification
- System or peripheral slot

Electrical Specifications

- Supply voltages
 - +12V (9.5..15.5V)
- Power consumption
 - The following values are valid for product model 02G052A00, which uses a T4240 processor.
 - +12V: 4 A nominal, 8 A maximum

Mechanical Specifications

- Dimensions
 - 3U, 4 HP
 - Weight: tbd (model tbd)

Environmental Specifications

- Temperature range (operation)
 - EN 50155 class T1, T2, T3 or TX
 - Airflow 2.5 m/s
 - Depends on system configuration (CPU, hard disk, heat sink...)
 - Temperature range (storage): -40°C to +85°C
- Cooling concept
 - Air-cooled, or
 - Conduction-cooled in MEN CCA frame
- Humidity: EN 60068-2-30, EN 50155
- Altitude: -300 m to +3000 m
- Shock: EN 50155 cat 1 class b
- Vibration: EN 50155 cat 1 class b

Reliability

- MTBF: tbd h @ 40°C according to IEC/TR 62380 (RDF2000) (model tbd)

Safety

- Flammability
 - UL 94V-0
- Electrical Safety
 - EN 62368-1 (former EN 60950-1)

EMC Conformity

- EN 55022 class B, EN 50121-3-2 (radiated and conducted emission)
- EN 55024, EN 50121-3-2 (immunity)

Software Support

- Linux
- For more information on supported operating system versions and drivers see Software.

BIOS

- U-Boot Universal Boot Loader

Germany

MEN Mikro Elektronik GmbH

Neuwieder Straße 3-7
90411 Nuremberg
Phone +49-911-99 33 5-0

sales@men.de
www.men.de

France

MEN Mikro Elektronik SAS

18, rue René Cassin
ZA de la Châtelaine
74240 Gaillard
Phone +33-450-955-312

sales@men-france.fr
www.men-france.fr

USA

MEN Micro Inc.

860 Penllyn Blue Bell Pike
Blue Bell, PA 19422
Phone 215-542-9575

sales@menmicro.com
www.menmicro.com

China

MEN Mikro Elektronik (Shanghai) Co., Ltd.

Room 808-809, Jiaying Mansion, No. 877 Dongfang Road
200122 Shanghai
Phone +86-21-5058-0961

sales@men-china.cn
www.men-china.cn

Up-to-date information, documentation and ordering information:

www.men.de/products/g52a/

The date of issue stated in this data sheet refers to the Technical Data only. Changes in ordering information given herein do not affect the date of issue. All brand or product names are trademarks or registered trademarks of their respective holders.

MEN is not responsible for the results of any actions taken on the basis of information in the publication, nor for any error in or omission from the publication. MEN expressly disclaims all and any liability and responsibility to any person, whether a reader of the publication or not, in respect of anything, and of the consequences of anything, done or omitted to be done by any such person in reliance, whether wholly or partially, on the whole or any part of the contents of the publication. The correct function of MEN products in mission-critical and life-critical applications is limited to the environmental specification given for each product in the technical user manual. The correct function of MEN products under extended environmental conditions is limited to the individual requirement specification and subsequent validation documents for each product for the applicable use case and has to be agreed upon in writing by MEN and the customer. Should the customer purchase or use MEN products for any unintended or unauthorized application, the customer shall indemnify and hold MEN and its officers, employees, subsidiaries, affiliates, and distributors harmless against all claims, costs, damages, and expenses, and reasonable attorney fees arising out of, directly or indirectly, any claim or personal injury or death associated with such unintended or unauthorized use, even if such claim alleges that MEN was negligent regarding the design or manufacture of the part. In no case is MEN liable for the correct function of the technical installation where MEN products are a part of.

© 2016 MEN