

CB30C

Vital Rugged COM Express Module with QorIQ P1022 ANSI-VITA 59 RCE Module

- » NXP QorIQ P1022 CPU
- » Up to 2 GB DDR3 SDRAM with ECC, soldered
- » Safe supervisor
- » Fail-safe board architecture
- » Event logging
- » SIL 2 with report from TÜV SÜD (EN 50128, EN 50129)
- » EN 50155, class TX compliance
- » -40°C to +85°C Tcase qualified
- » Conduction cooling
- » Conformal coating
- » VITA 59 (in pr.), compliant with COM Express Basic, type 6
- » PICMG COM.0 COM Express version also available

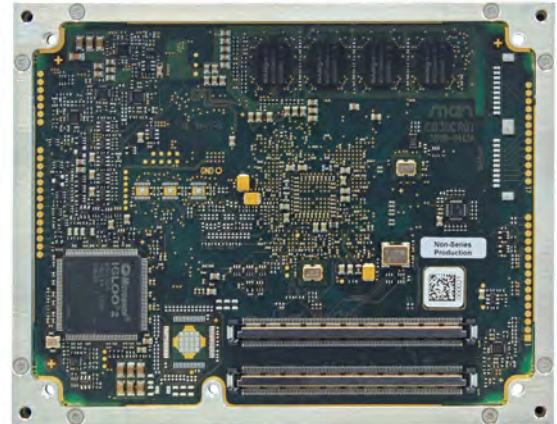

Safe CPU System up to SIL 2

The CB30C safe CPU board is a Rugged COM Express module for use in safety-related applications, e.g., for rolling-stock train control systems or industrial applications. It is based on a NXP QorIQ single-core P1013 or dual-core P1022 processor, running at up to 1 GHz and providing excellent performance per watt. It is hardware-supervised by a dedicated safe supervisor to meet EN 50129 or IEC 61508 SIL 2 level requirements. An assessment report from TÜV SÜD greatly simplifies certification for railway applications.

Functional Safety Architecture: Fail-Safe

The CB30C is a single-processor board with a fail-silent design. The functional safety architecture is based on monitoring all safe CPU subsystem environmental conditions, e.g., voltages and temperature. If safe operation of the CPU subsystem cannot be guaranteed, the safe supervisor (SUPV) removes the power of the subsystem, ensuring all external communications are stopped. The SUPV also ensures it is only possible to exit the safe state in a controlled manner. If an overvoltage is detected the CB30C is placed in a non-recoverable disabled state and needs to be shipped to MEN for inspection before possibly returning to the field. An onboard event logger helps to analyze errors while reducing software overhead.

Rugged COM Design for Harsh Environments

The computer-on-module comes in a robust aluminum cooling frame and cover that shields the COM against EMC and provides a cooling interface for integration in fanless systems. With all components soldered, its small form factor and low power consumption, the board is ideal for embedded applications in severe environments. Its full EN 50155 compliance up to class TX gives it a focus on rolling-stock applications.

Solid Connectivity and I/O

With its focus on safe design, the CB30C still offers ample I/O functionality, including two or three Gigabit Ethernet and PCI Express interfaces, two SATA channels, up to four USB 2.0 ports, UARTs and general-purpose I/O. DVI or LVDS can be implemented for graphics functions. Up to 2 GB DDR3 SDRAM with ECC support and a soldered eMMC storage device round out the CPU.

Standardized VITA 59, COM Express based

Being a VITA 59 standard computer-on-module, the CB30C complies with the COM Express Basic form factor and type 6 pin-out. A COM.0 COM Express version is also on offer.

For evaluation and development purposes a microATX carrier board, the XC15, is available.

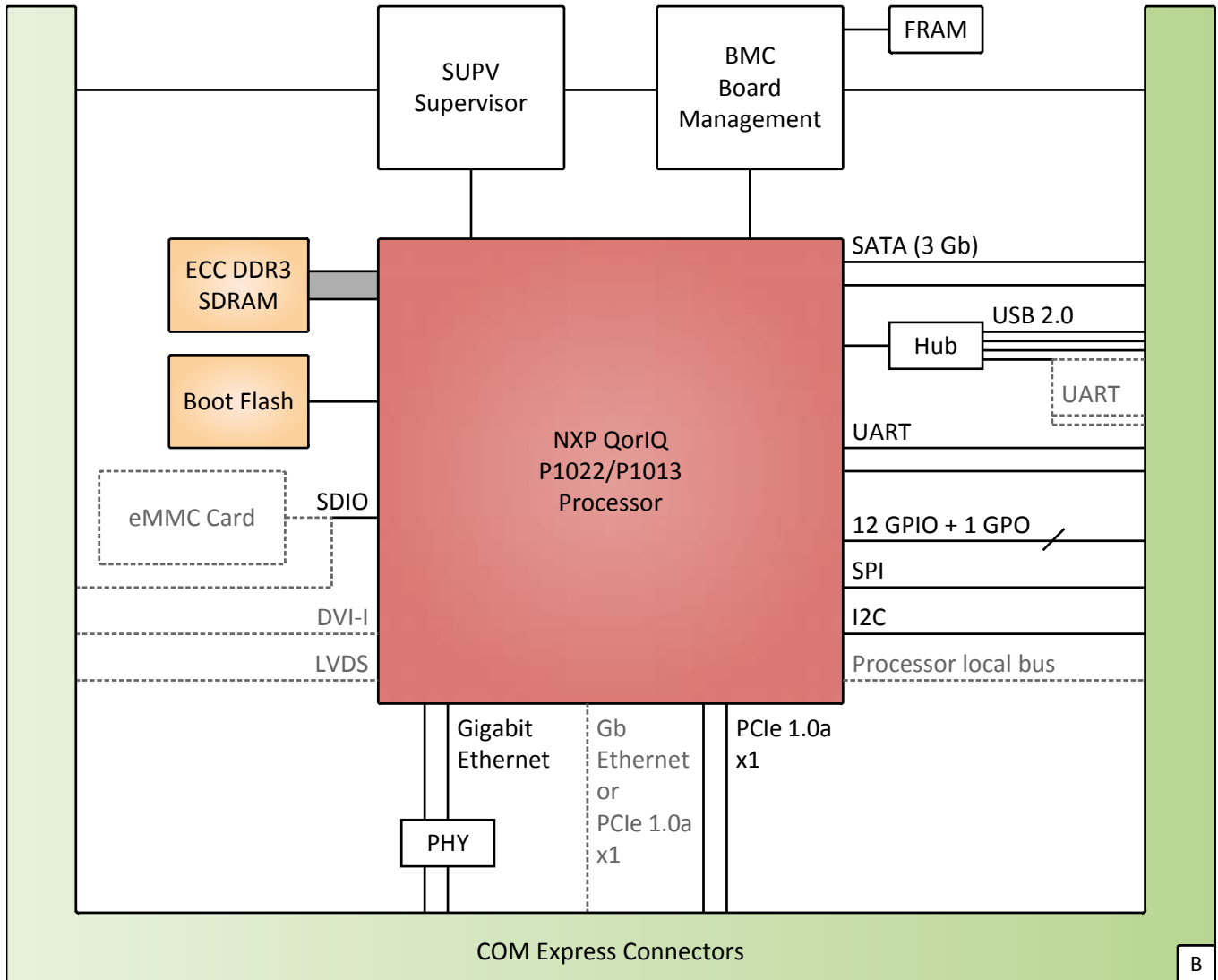

B Onboard Options

CPU

- The following CPU types are supported:
 - NXP QorIQ P1022, dual core, 800 MHz
 - NXP QorIQ P1022, dual core, 1 GHz
 - NXP QorIQ P1022, dual core, 1.2 GHz, with reduced temperature range
 - NXP QorIQ P1013, single core, 800 MHz
 - NXP QorIQ P1013, single core, 1 GHz
 - NXP QorIQ P1013, single core, 1.2 GHz, with reduced temperature range

Memory

- System Memory
 - Soldered DDR3, ECC support
 - 1 GB, or 2 GB
- Boot Flash
 - 32 MB, 64 MB, or 128 MB
- 8 KB non-volatile FRAM for event logging

Mass Storage

- The following mass storage devices can be assembled:
 - eMMC device, soldered; different sizes available

Graphics

- Optional
- Integrated in QorIQ processor
- Maximum resolution: 1280 x 1024 pixels
- 60 Hz refresh rate
- 24 bpp color depth

Onboard Interfaces

- Available via COM Express connectors
- SATA
 - Two channels, SATA Revision 2.x
- SDIO/SDHC
 - One channel for MMC/SD/SDIO cards; optional
- Video
 - One DVI interface; optional
 - One LVDS interface, single-channel; optional
- USB
 - Four host channels, USB 2.0, or
 - Three host channels, USB 2.0
- Ethernet
 - Two channels, 1000BASE-T, or
 - Three channels, 1000BASE-T
 - Link and activity LED signals for each channel
- PCI Express
 - Three x1 links, PCIe 1.0a, or
 - Two x1 links, PCIe 1.0a
- ExpressCard
 - One interface
- UART
 - Two interfaces, or
 - Four interfaces
 - Physical interfaces RS232 or RS422/RS485 depending on implementation on carrier board
- I2C
 - One I2C interface
- SPI
 - One SPI interface
- GPIO
 - 12 GPIO lines
 - 1 GPO line
- Processor local bus; optional

Supervision and Control

- Safe supervisor
 - Check for overvoltage, undervoltage, excess temperature, CPU clock
 - Watchdog, configurable as a window or timeout watchdog
- Event logging
 - Event history logged in non-volatile FRAM, e.g., reset, overvoltage, undervoltage, excess temperature
 - 256 entries possible
 - Events are generated by board hardware or user application
- Real-time clock, with supercapacitor or battery backup on the carrier board
 - Up to year 2199

Computer-On-Module Standard

- CB30C: VITA 59 RCE: Rugged COM Express in process
 - With conduction cooling cover and frame
 - Rugged COM Express Basic, Module Pin-out Type 6
- CB30: PICMG COM.0 COM Express Module Base Specification
 - COM Express Basic, Module Pin-out Type 6

Electrical Specifications

- Supply voltage
 - +12 V (9 to 14 V)
- Power consumption
 - 15 W typ.

Mechanical Specifications

- Dimensions
 - 135 mm x 105 mm x 18 mm (models conforming to VITA 59 RCE Basic format, PCB mounted between a cover and a frame)
 - 125 mm x 95 mm (models conforming to PICMG COM.0 COM Express Basic format)
- Weight
 - 470 g (model 15CB30C00)

Environmental Specifications

- Temperature range (operation)
 - -40°C to +85°C Tcase (VITA 59 cover/frame) (qualified components), compliant with EN 50155, class TX (model 15CB30C00)
 - -40°C to +85°C (qualified components), compliant with EN 50155, class TX (model 15CB30-00)
- Temperature range (storage): -40°C to +85°C
- Cooling concept
 - Conduction-cooled (models conforming to VITA 59 RCE Compact format, PCB mounted between a cover and a frame)
 - Air-cooled (models conforming to PICMG COM.0 COM Express Compact format)
- Relative humidity (operation): max. 95% with condensation (EN 50155 / EN 60068-2-30)
- Relative humidity (storage): max. 95% with condensation (EN 50155 / EN 60068-2-30)
- Altitude: -300 m to +3000 m
- Shock: EN 50155 (12.2.11) / EN 61373 category 1 class B body mounted
- Vibration: EN 50155 (12.2.11) / EN 61373 category 1 class B body mounted
- Conformal coating

Reliability

- MTBF
 - 724 561 h @ 40°C according to IEC/TR 62380 (RDF 2000) (model 15CB30C00, 15CB30-00)

Safety

- Functional Safety
 - Certifiable up to SIL 2 according to EN 50128 / EN 50129 ("safety case" document and certificate from TÜV SÜD)
 - Tolerable hazard rate (THR) for safety functions $< 0.5 \cdot 10E-7 / h$
 - Diagnostic coverage: 90% min.
 - Board maintains safe state after a failure
- Electrical Safety
 - EN 60950-1, class III equipment
- Flammability (PCBs)
 - UL 94 V-0
- Fire Protection
 - EN 45545, hazard level 3
 - NFPA 130, category "other vehicle components"

EMC

- EMC behavior generally depends on the system and housing surrounding the COM module.
- The Rugged COM Express module in its cover and frame supports the system to meet the requirements of
 - EN 50121-3-2, class B
 - EN 50121-4
 - EN 55022

BIOS

- U-Boot Universal Boot Loader

Software Support

- Linux
- VxWorks (on request)
- [For more information on supported operating system versions and drivers see Software.](#)

Germany

MEN Mikro Elektronik GmbH

Neuwieder Straße 3-7
90411 Nuremberg
Phone +49-911-99 33 5-0

sales@men.de
www.men.de

USA

MEN Micro Inc.

860 Penllyn Blue Bell Pike
Blue Bell, PA 19422
Phone 215-542-9575

sales@menmicro.com
www.menmicro.com

France

MEN Mikro Elektronik SAS

18, rue René Cassin
ZA de la Châtelaine
74240 Gaillard
Phone +33-450-955-312

sales@men-france.fr
www.men-france.fr

China

MEN Mikro Elektronik (Shanghai) Co., Ltd.

Room 808-809, Jiaxing Mansion, No. 877 Dongfang Road
200122 Shanghai
Phone +86-21-5058-0961

sales@men-china.cn
www.men-china.cn

Up-to-date information, documentation and ordering information:

www.men.de/products/cb30c/

The date of issue stated in this data sheet refers to the Technical Data only. Changes in ordering information given herein do not affect the date of issue. All brand or product names are trademarks or registered trademarks of their respective holders.

MEN is not responsible for the results of any actions taken on the basis of information in the publication, nor for any error in or omission from the publication.

MEN expressly disclaims all and any liability and responsibility to any person, whether a reader of the publication or not, in respect of anything, and of the consequences of anything, done or omitted to be done by any such person in reliance, whether wholly or partially, on the whole or any part of the contents of the publication.

The correct function of MEN products in mission-critical and life-critical applications is limited to the environmental specification given for each product in the technical user manual. The correct function of MEN products under extended environmental conditions is limited to the individual requirement specification and subsequent validation documents for each product for the applicable use case and has to be agreed upon in writing by MEN and the customer. Should the customer purchase or use MEN products for any unintended or unauthorized application, the customer shall indemnify and hold MEN and its officers, employees, subsidiaries, affiliates, and distributors harmless against all claims, costs, damages, and expenses, and reasonable attorney fees arising out of, directly or indirectly, any claim or personal injury or death associated with such unintended or unauthorized use, even if such claim alleges that MEN was negligent regarding the design or manufacture of the part.

In no case is MEN liable for the correct function of the technical installation where MEN products are a part of.

© 2017 MEN Holding