

# A20 – 6U VMEbus 2eSST Intel® Core™ 2 Duo CPU Board

- Intel® Core™ 2 Duo L7400
- Core Duo U2500 or L2400
- 1-slot 2eSST VMEbus master and slave
- Up to 4 GB DDR2 DRAM soldered
- 2 SATA, 1 PATA interface
- 1 VGA at front
- 1 Gb Ethernet at front
- 1 USB at front
- 2 XMC or 2 PMC
- PCI Express® six x1 links
- Board controller

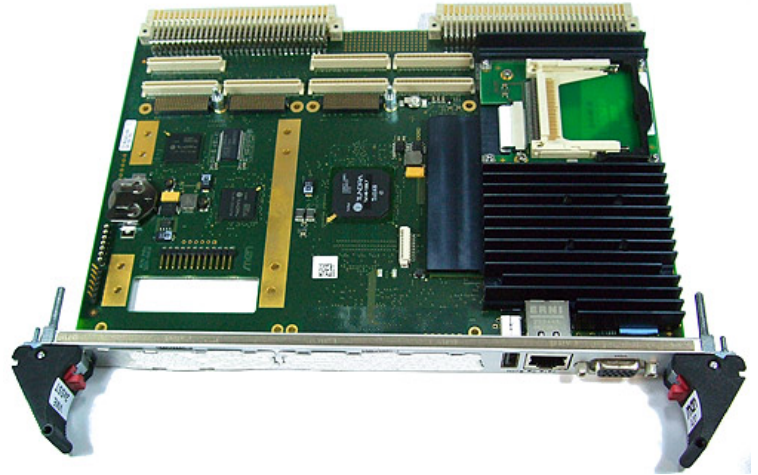

The A20 6U single-slot VMEbus SBC supports a variety of Intel® Core™ Duo and Core 2 Duo processors from the high-end 1.5 GHz L7400 to the low-voltage dual-core versions down to a selection of single-core Celeron® M types. It is designed especially for systems which require high computing and graphics performance and low power consumption in a typical Windows® environment, under VxWorks® or Linux. Using the TS1148 bridge controller the CPU card provides 2eSST performance levels while maintaining backwards compatibility with older standards such as VME64 and VME32.

The standard I/O available at the front panel of the A20 includes graphics on a VGA connector, one Gigabit Ethernet and one USB 2.0 interface. As an option a COM interface on an RJ45 connector can be provided instead of the USB interface.

As rear I/O the A20 provides seven USB interfaces, one SATA port and PMC rear I/O.

A second SATA interface for connection of an onboard hard disk or for building up RAID systems is provided on-board instead of one PMC or XMC. One PATA interface supports the onboard CompactFlash® slot. The working memory comprises up to 4 GB DDR2 DRAM which is soldered to guarantee optimum shock and vibration resistance.

A total of six PCI Express® lanes for high-speed communication (such as Gb Ethernet) are supported

on the A20. One x1 PCIe® link is used for the onboard Ethernet interface, three x1 links support the XMC slots, one x1 link supports the PMC slots via a PCI Express® to PCI-X bridge and one x1 link is used for connection of the VMEbus bridge. The PMC slots support 64bit/66MHz (PCI-X).

Supervision of the processor and board temperature as well as a watchdog for monitoring the operating system complete the functionality of the SBC.

The A20 comes with a tailored passive heat sink within 4 HP height. However, forced air cooling is always required inside the system.

Equipped with Intel® components exclusively from the Intel® Embedded Line, the A20 has a guaranteed minimum standard availability of 5 years.

Its robust design make the A20 especially suited for rugged environments with regard to extended operating temperature, shock and vibration according to applicable DIN, EN or IEC industry standards. It is also ready for coating for use in humid and dusty environments. The wide range of industrial applications include for example monitoring, vision and control systems as well as test and measurement. Main target markets comprise industrial automation, security and infotainment, traffic and transportation, shipbuilding, medical engineering and robotics.

# Diagram

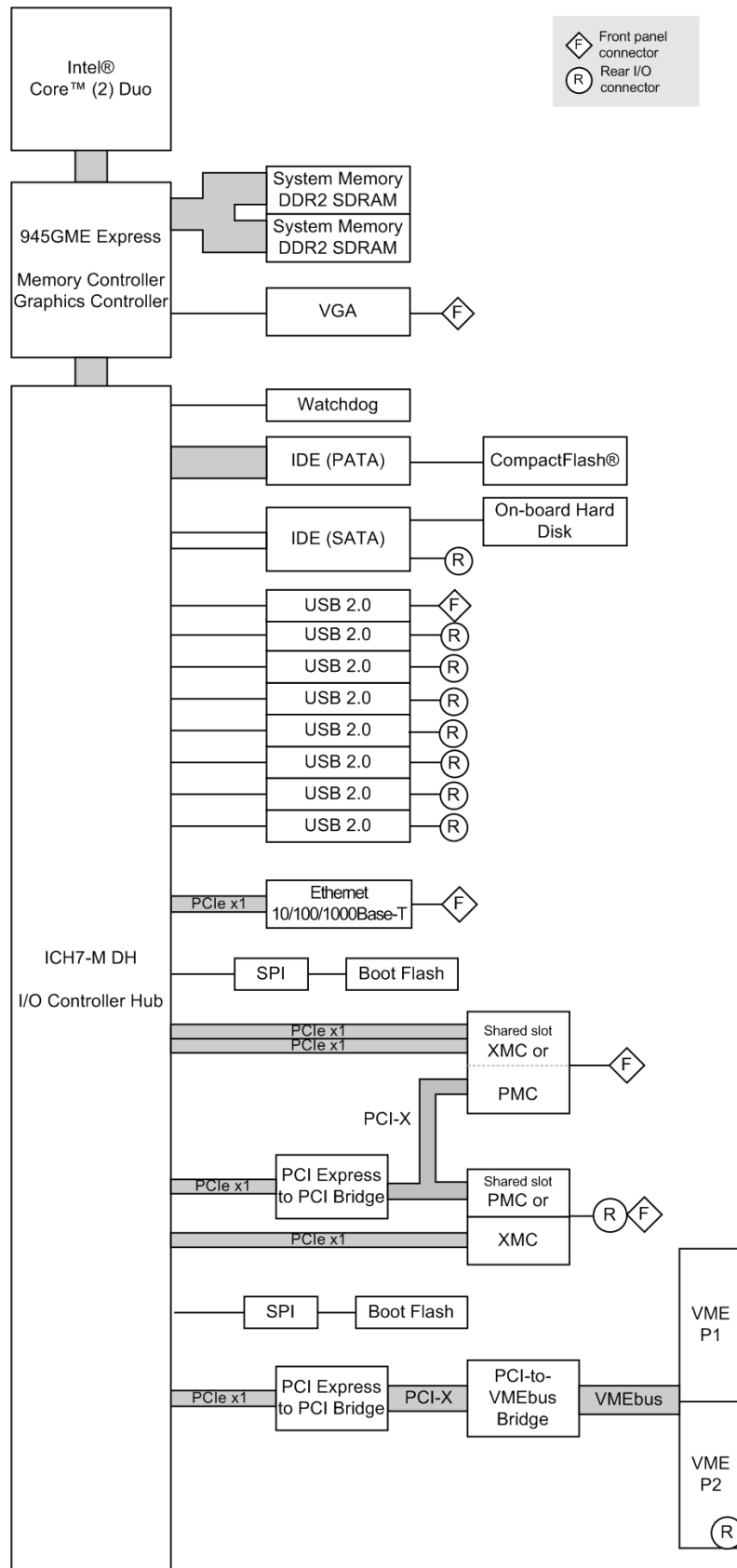

## Technical Data

<b>CPU</b>	<ul style="list-style-type: none"><li>■ Up to Intel® Core™ 2 Duo L7400<ul style="list-style-type: none"><li>□ Dual-core 64-bit processor</li><li>□ Up to 1.5GHz processor core frequency</li><li>□ Up to 667MHz front-side bus frequency</li></ul></li><li>■ Chipset<ul style="list-style-type: none"><li>□ Northbridge: Intel® 945GME Express</li><li>□ Southbridge: Intel® ICH7-M DH</li></ul></li></ul>
<b>Memory</b>	<ul style="list-style-type: none"><li>■ 4MB L2 cache integrated in Core 2 Duo</li><li>■ Up to 4GB SDRAM system memory<ul style="list-style-type: none"><li>□ Soldered</li><li>□ DDR2</li><li>□ 667MHz memory bus frequency</li><li>□ Dual-channel, 2x64 bits</li></ul></li><li>■ CompactFlash® card interface<ul style="list-style-type: none"><li>□ Via onboard IDE</li><li>□ Type I</li><li>□ True IDE</li><li>□ DMA support</li></ul></li><li>■ 8Mbits boot Flash</li><li>■ Serial EEPROM 2kbits for factory settings</li></ul>
<b>Mass Storage</b>	<ul style="list-style-type: none"><li>■ Parallel IDE (PATA)<ul style="list-style-type: none"><li>□ One IDE port for local CompactFlash®</li></ul></li><li>■ Serial ATA (SATA)<ul style="list-style-type: none"><li>□ One channel for onboard hard disk</li><li>□ One channel via rear I/O connector P2</li><li>□ Transfer rates up to 150MB/s</li><li>□ RAID level 0/1 support</li></ul></li></ul>
<b>Graphics</b>	<ul style="list-style-type: none"><li>■ Integrated in 945GME Express chipset<ul style="list-style-type: none"><li>□ 200/250MHz 256-bit graphics core</li></ul></li><li>■ VGA connector at front panel</li></ul>
<b>I/O</b>	<ul style="list-style-type: none"><li>■ USB<ul style="list-style-type: none"><li>□ One USB 2.0 port via Series A connector at front panel</li><li>□ Seven USB 2.0 ports via rear I/O</li><li>□ UHCI implementation</li><li>□ Data rates up to 480Mbit/s</li></ul></li><li>■ Ethernet<ul style="list-style-type: none"><li>□ One 10/100/1000Base-T Ethernet channel at front panel</li><li>□ RJ45 connector at front panel</li><li>□ Ethernet controller connected by one x1 PCIe® link</li><li>□ Onboard LEDs to signal activity status and connection speed</li></ul></li></ul>
<b>Front Connections</b>	<ul style="list-style-type: none"><li>■ VGA</li><li>■ One USB 2.0 (Series A)</li><li>■ One Ethernet (RJ45)</li></ul>
<b>Rear I/O</b>	<ul style="list-style-type: none"><li>■ USB 2.0, seven ports</li><li>■ PMC rear I/O (for one PMC)</li><li>■ One SATA channel</li></ul>

## Technical Data

### Mezzanine Slot

- Two slots usable for PMC or XMC
- XMC slots
  - Compliant with XMC standard VITA 42.3-2006
  - Two x1 PCI Express® links for slot 2
  - One x1 PCI Express® link for slot 1
- PMC slots
  - Compliant with PMC standard IEEE 1386.1
  - PCI / PCI-X 32/64 bit, 33/66MHz, 3.3V V(I/O)
  - One x1 PCI Express® link via PCI Express® to PCI-X bridge
  - PMC I/O module (PIM) support (for one PMC)
  - Current limited to 2A for 5V and 3.3V

### Miscellaneous

- Board controller
- Real-time clock, buffered by a GoldCap and a battery
- Watchdog timer
- Temperature measurement
- One user LED
- Reset button

### PCI Express®

- One x1 link to connect local 1000Base-T Ethernet controller
- Three x1 links to connect XMC
- One x1 link to connect PMC via PCI Express® to PCI-X bridge
- One x1 link to connect the VME bridge via a PCI Express® to PCI-X bridge
- Data rate up to 250MB/s in each direction (2.5 Gbit/s per lane)

### VMEbus

- IDT TS1148 controller
- Compliant with VME64 Specification
- Supports VME32, VME64, 2eVME and 2eSST (VITA 1.5)
- Maximum data rate 250 MB/s (limited by PCI Express® link)
- Slot-1 function with auto-detection
- Master
  - D08:D16:D32:D64:A16:A24:A32:A64:BLT:MBLT:RMW
- Slave
  - D08:D16:D32:D64:A16:A24:A32:A64:BLT:MBLT
- DMA
- Mailbox functionality
- Bus timer
- Location Monitor
- Interrupter D08(O):I(7-1):ROAK
- Interrupt handler D08(O):IH(7-1)
- Single level 3 fair requester
- Single level 3 arbiter

### Electrical Specifications

- Supply voltage/power consumption:
  - +5V (-3%/+5%), 3.2A (idle)..6.6A (full load)
  - 3.3V for XMC/PMC are generated on the board

### Mechanical Specifications

- Dimensions: standard double Eurocard, 233.3mm x 160mm
- Front panel: 4HP with ejector
- Weight:
  - Without XMC/PMCs: 525g

## Technical Data

---

### Environmental Specifications

- Temperature range (operation):
  - 0..+60°C
  - Airflow: min. 1.5m/s
- Temperature range (storage): -40..+85°C
- Relative humidity (operation): max. 95% non-condensing
- Relative humidity (storage): max. 95% non-condensing
- Altitude: -300m to + 3,000m
- Shock: 15g/11ms (EN 60068-2-27)
- Bump: 10g/16ms (EN 60068-2-29)
- Vibration (sinusoidal): 1g/ 10..150Hz (EN 60068-2-6)
- Conformal coating on request

### MTBF

- 190,571h @ 40°C according to IEC/TR 62380 (RDF2000)

### Safety

- PCB manufactured with a flammability rating of 94V-0 by UL recognized manufacturers

### EMC

- Tested according to EN 55022 Class A (radio disturbance), EN 61000-4-2 (ESD), EN 61000-4-4 (burst) and EN 61000-4-5 (surge)

### BIOS

- Award BIOS

### Software Support

- Windows®
- Linux
- VxWorks®
- QNX® (on request)
- Intel® Virtualization Technology, allows a platform to run multiple operating systems and applications in independent partitions; one computer system can function as multiple "virtual" systems
- [For more information on supported operating system versions and drivers see Downloads.](#)

## Configuration & Options

### Standard Configurations

Article No.	CPU Type	System RAM	XMC/PMC	P0 Ethernet	Operation Temp.
01A020-00	L7400	2 GB DDR2	2 slots	No	0..+60°C

### Options

<b>CPU</b>	<ul style="list-style-type: none"> <li>■ Core 2 Duo L7400, 1.5GHz LV</li> <li>■ Core Duo L2400, 1.66GHz LV</li> <li>■ Core Duo U2500, 1.2GHz ULV</li> <li>■ Celeron® M 423, 1.06 GHz</li> </ul>
<b>Memory</b>	<ul style="list-style-type: none"> <li>■ System RAM                             <ul style="list-style-type: none"> <li>□ 512 MB, 1 GB, 2 GB or 4 GB</li> </ul> </li> <li>■ CompactFlash®                             <ul style="list-style-type: none"> <li>□ 0 MB up to maximum available</li> </ul> </li> </ul>
<b>I/O</b>	<ul style="list-style-type: none"> <li>■ UART (instead of front USB and one PCI Express® link)                             <ul style="list-style-type: none"> <li>□ One RS232 via adapter cable (see Accessories)</li> <li>□ One RJ45 connector at front panel</li> <li>□ Data rates 300bit/s..230kbit/s</li> <li>□ FIFO receive and transmit buffers for high data throughput</li> <li>□ Handshake lines: full support</li> </ul> </li> </ul>

Please note that some of these options may only be available for large volumes. Please ask our sales staff for more information.

## Ordering Information

<b>Standard A20 Models</b>	<b>01A020-00</b>	Intel® Core™ 2 Duo L7400, 1.5 GHz, 2 GB DDR2 DRAM, P0 not mounted, 0..+60°C
<b>Memory</b>	<b>0751-0045</b>	CompactFlash® card, 4 GB, Type I, fixed bit set, -40..+85°C
	<b>0751-0055</b>	CompactFlash® card, 8 GB, Type I, fixed bit set, -40..+85°C
	<b>0751-0060</b>	CompactFlash® card, 16 GB, -40..+85°C
	<b>0751-0061</b>	CompactFlash® card, 2 GB, Type I, fixed bit set, -40 to +85°C
<b>Miscellaneous Accessories</b>	<b>05F006-00</b>	RS232 interface cable RJ45 to 9-pin D-Sub (1 COM to 1 COM), 2m
	<b>05P000-01</b>	25 mounting screw sets to fix PMC/XMC modules on carrier boards
<b>Software: Linux</b>	This product is designed to work under Linux. See below for all available separate software packages.	
	<b>13MD05-90</b>	MDISS System (and Device Driver) Package (MEN) for Linux. This software package includes most standard device drivers available from MEN.
	<b>13Z014-90</b>	Linux device driver (MEN) for PCI-to-VME bridge on A12, A13, A14, A15, A17, A19, A20, A21B/A21C and B11
<b>Software: Windows®</b>	This product is designed to work under Windows®. See below for all available separate software packages.	
	<b>13F014-77</b>	Windows® Installset (MEN) for F14, F15, F17, F18, D9, D601, A19 and A20 (Includes all free drivers developed by MEN for the supported hardware.)
	<b>13T001-70</b>	Windows® network driver (Intel®) for F14, F15, F17, F18, D9, D6, D7, D601, A19, A20 and P601, P602
	<b>13T003-70</b>	Windows® chipset driver (Intel®) for F14, F15, F17, F18, F18E, F19P, F21P, F22P, G20, G22, XM2, CB70C, D9, D6, D7, D601, A19 and A20
	<b>13T005-70</b>	Windows® USB2UART driver (FTDI) for F14, F15, F17, F18, F19P, F21P, F22P, F23P, D9, A19, A20, XM2 and XM50 / XM51 / F50P / F50C hosts
	<b>13T007-70</b>	Windows® chipset graphics driver (Intel®) for F15, F17, D9, A19 and A20
	<b>13Z014-71</b>	VME4WIN/MDISS Software Package (MEN) - VMEbus support under Windows® XP/Vista/Windows® 7 for MEN A19 and A20
<b>Software: VxWorks®</b>	This product is designed to work under VxWorks®. For details regarding supported/unsupported board functions please refer to the corresponding software data sheets.	
	<b>10A019-60</b>	VxWorks® 6.6 BSP for A19 and A20
	<b>13Y001-06</b>	MDISS low-level driver sources (MEN) for LM63 on SMBus for F14, F15, F17, F18, F19P, D9, D601, A19 and A20
	<b>13Y002-06</b>	MDISS low-level driver sources (MEN) for F14, F15, F17, F18, D9, D601, A19 and A20 board monitoring
	<b>13Y004-06</b>	MDISS low-level driver sources (MEN) for generic SMBus driver for F14, F15, F17, F18, F19P, F21P, F22P, G20, G22, D9, D601, F600 and F601, A19, A20, F217, CB70C, SC24, BC50M, BC50I and BL50W
	<b>13Y007-06</b>	MDISS low-level driver sources (MEN) for F14, F15, F17, F18, D9, D601, A19 and A20 board controller
<b>Software: Firmware/BIOS</b>	This product includes a specially adapted BIOS.	
	<b>14A020-00</b>	System BIOS for A19 and A20

## Ordering Information

### Software: Miscellaneous

Intel® software development products such as analyzers, compilers, threading tools etc. can be downloaded under [www.intel.com/cd/software/products/asmo-na/eng/index.htm](http://www.intel.com/cd/software/products/asmo-na/eng/index.htm). IA-32 Intel® Architecture Software Developer's Manuals are available under [www.intel.com/products/processor/manuals/index.htm](http://www.intel.com/products/processor/manuals/index.htm).

For operating systems not mentioned here [contact MEN sales](#).

### Documentation

Compare Chart 6U VMEbus CPU and I/O cards » [Download](#)

#### 20A020-00

A20 User Manual

#### 20A020-ER

A20 Errata

#### 21APPN016

Application Note: Accessing SMBus under Linux Kernel 3.2 on MEN Intel® Boards

## Contact Information

### Germany

MEN Mikro Elektronik GmbH  
Neuwieder Straße 3-7  
90411 Nuremberg  
Phone +49-911-99 33 5-0  
Fax +49-911-99 33 5-901

info@men.de  
www.men.de

### France

MEN Mikro Elektronik SAS  
18, rue René Cassin  
ZA de la Châtelaine  
74240 Gaillard  
Phone +33 (0) 450-955-312  
Fax +33 (0) 450-955-211

info@men-france.fr  
www.men-france.fr

### USA

MEN Micro Inc.  
860 Penllyn Blue Bell Pike  
Blue Bell, PA 19422  
Phone (215) 542-9575  
Fax (215) 542-9577

sales@menmicro.com  
www.menmicro.com

*The date of issue stated in this data sheet refers to the Technical Data only. Changes in ordering information given herein do not affect the date of issue. All brand or product names are trademarks or registered trademarks of their respective holders.*

*MEN is not responsible for the results of any actions taken on the basis of information in the publication, nor for any error in or omission from the publication.*

*MEN expressly disclaims all and any liability and responsibility to any person, whether a reader of the publication or not, in respect of anything, and of the consequences of anything, done or omitted to be done by any such person in reliance, whether wholly or partially, on the whole or any part of the contents of the publication.*

*The correct function of MEN products in mission-critical and life-critical applications is limited to the environmental specification given for each product in the technical user manual. The correct function of MEN products under extended environmental conditions is limited to the individual requirement specification and subsequent validation documents for each product for the applicable use case and has to be agreed upon in writing by MEN and the customer. Should the customer purchase or use MEN products for any unintended or unauthorized application, the customer shall indemnify and hold MEN and its officers, employees, subsidiaries, affiliates, and distributors harmless against all claims, costs, damages, and expenses, and reasonable attorney fees arising out of, directly or indirectly, any claim or personal injury or death associated with such unintended or unauthorized use, even if such claim alleges that MEN was negligent regarding the design or manufacture of the part.*

*In no case is MEN liable for the correct function of the technical installation where MEN products are a part of.*

Copyright © 2015 MEN Mikro Elektronik GmbH. All rights reserved.